



**Laser welding and bonding
as alternative technology
for stitch-free seams**



Leister Technologies AG, BU Laser Plastic Welding

We know how.

1. Introduction to laser joining process
2. Design rules for laser
3. Direct laser weld seam
4. Laser bonding
5. Laser taping of seams
6. Laminating membranes
7. Laser safety
8. Examples
 - inflatable jacket
 - wind-stopper
 - Cool-pads



Welding textiles with hot-air & hot wedge

Traditional methods established in market

- mostly welding of plastic coating and not textile fabric itself



Moving versus stationary machine concept

Depends on geometry of end product



Hot-air welding machine (Uniplan)
driving over laid-out truck covers



3D image stationary welding machine
(Seamtek – since lately part of Leister)

- large and heavy textiles best welded on floor or table with welding machine moving self-propelled over seams
- small work-pieces with precise seams and curvatures best welded on stationary machine with manual feeding

1. Introduction to laser joining process

Type of welding distinguished by type of energy deposition

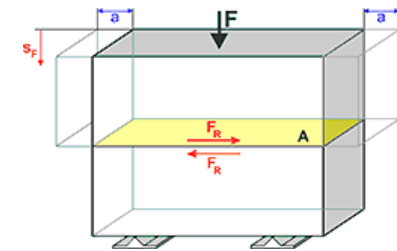
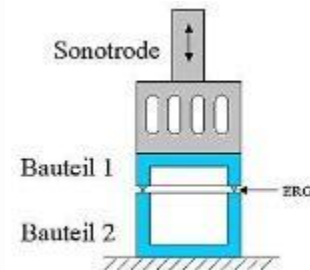
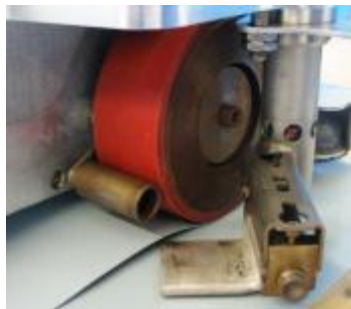
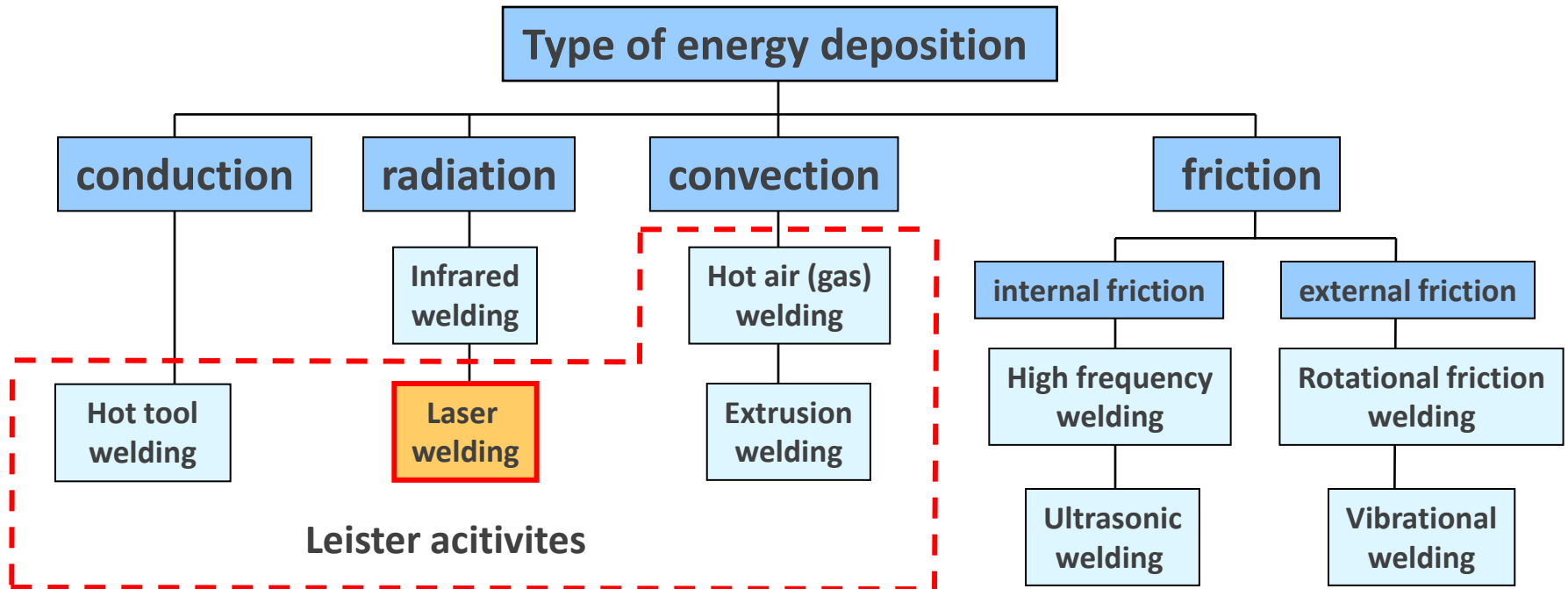

1. Introduction to laser joining process

Laser welding versus laser induced bonding

Laser welding

- laser absorbed by lower material
- upper transparent material not affected
- heat conducted to upper material by physical contact
- small and precise melting zone
- no mechanical movement or strain
- both from same or compatible polymers:
 - similar melting temperature
 - chemically miscible

necessary for both:

- energy into material
- contact and pressure
- time to mix and cool

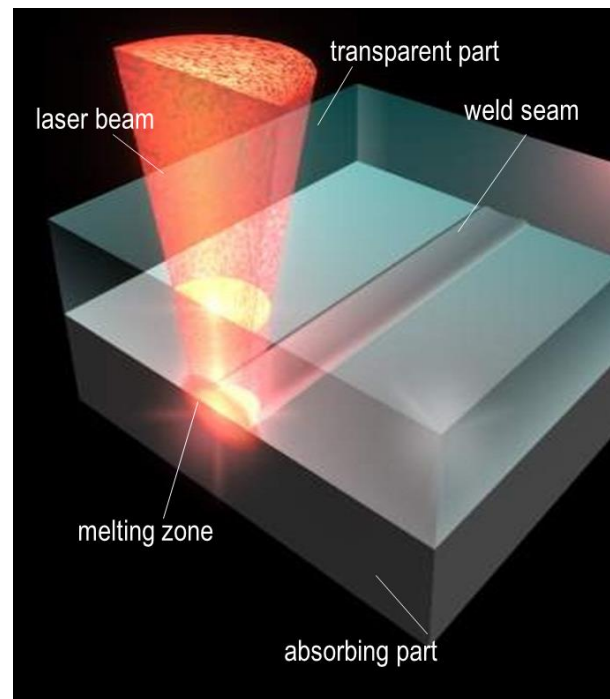

Laser bonding:

- adhesive activated by laser energy
- upper and lower material not affected as transparent to laser
- precise local energy deposition
- possible to join dissimilar material
- possible to join also natural fibers (non thermo-plastic)
- with tape additional material necessary

1. Introduction to laser joining process

Established since many years for injection molded parts & foils

Target markets:

- Automotive
- Medical parts
- Consumer Electronics
- ...



Advantages:

- small local heat affective zone
- no induced mechanical strain in part
- no flash or particles from polymer melt
- no emission from laser process



1. Introduction to laser joining process

Various standard processes to apply laser light

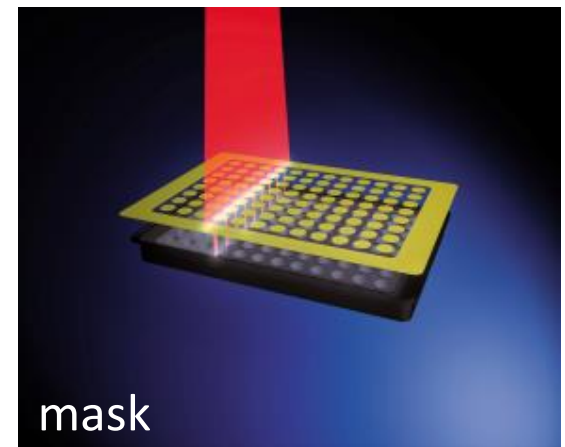
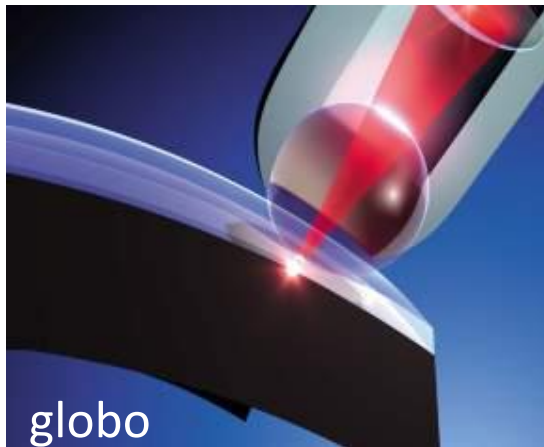

1. Introduction to laser joining process

Suited for textiles: ROLLER

- roller lens focuses laser beam and applies pressure
- for movement in one direction: Roller
- large work pieces possible
- optical fiber from laser source to optic head

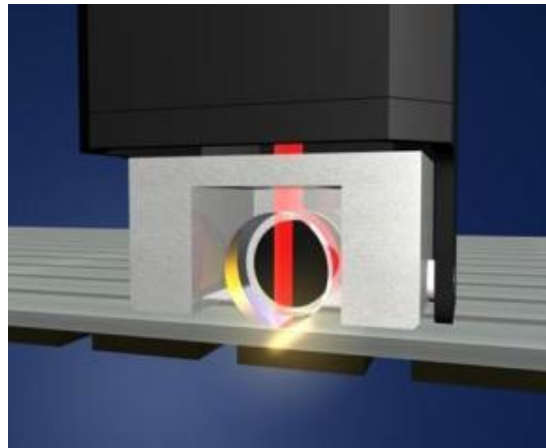

1. Introduction to laser joining process

Suited for textiles: GLOBO

- ball as lens focuses laser beam and applies pressure
- for movement in 2 dimensions: Globo ball with air bearing
- large work pieces possible
- optical fiber from laser source to optic head

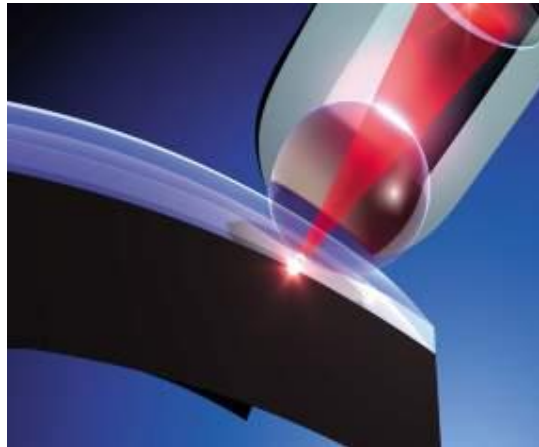

1. Introduction to laser joining process

Suited for textiles: Mask

- focused laser line
- pressure applied by clamping unit
- precise repeatable welding information in 2D mask
- limited work piece sizes
- Laser integrated in optic head

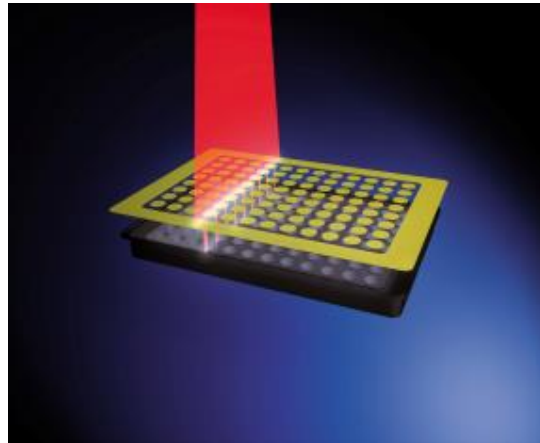

1. Introduction to laser joining process

Various possibilities for integration into a system

- for large 2-dimensional part integrated on cutting table
- mounted in a modified sewing machine
- integrated into a special machine
- Leister turn-key Workstation or Tabletop

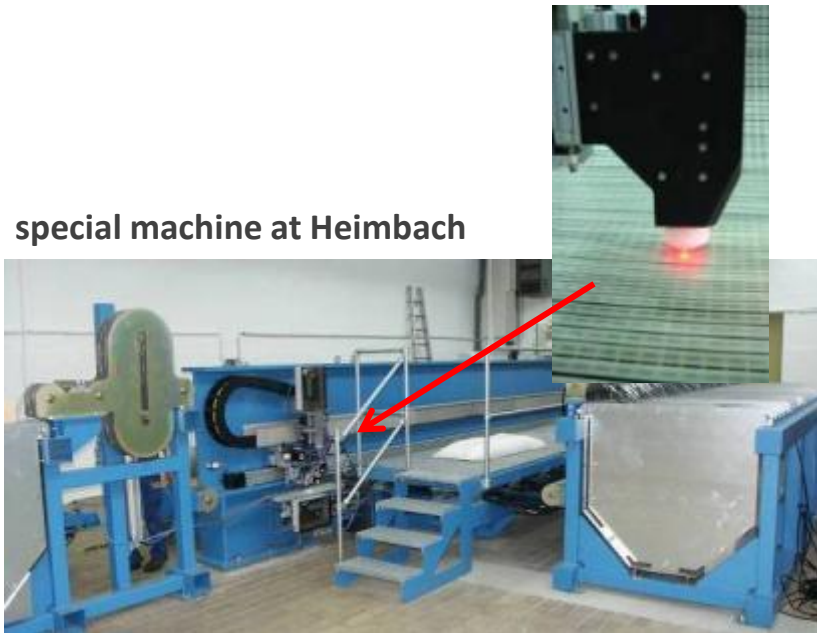

2. Design rules for laser process

Which layer is transparent to laser and which absorbing?

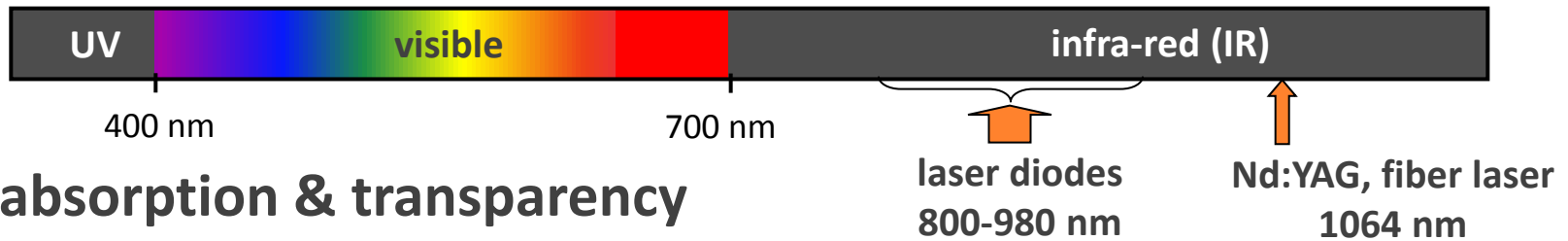

- **absorption & transparency for laser and color for eye independently adjustable**
- **textiles:**
 - most textiles laser transparent - also it looks black to us
 - special laser-absorbing dyes expensive
 - it matters which layer is at top or bottom
 - coloring membrane in laminate easier than textile layer itself
 - additional laser-absorbing ribbon possible

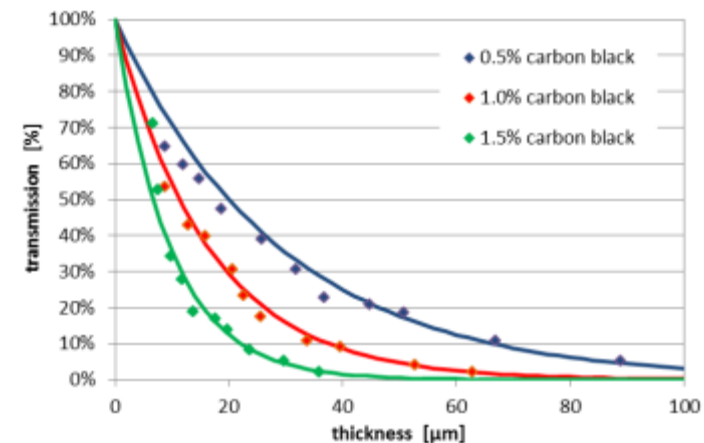
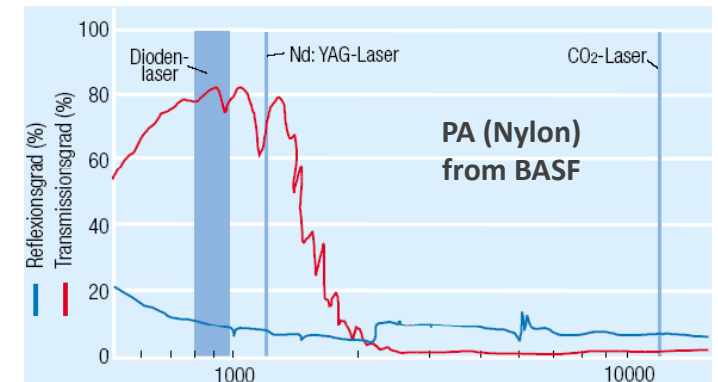

2. Design rules for laser process

Example black but laser transparent

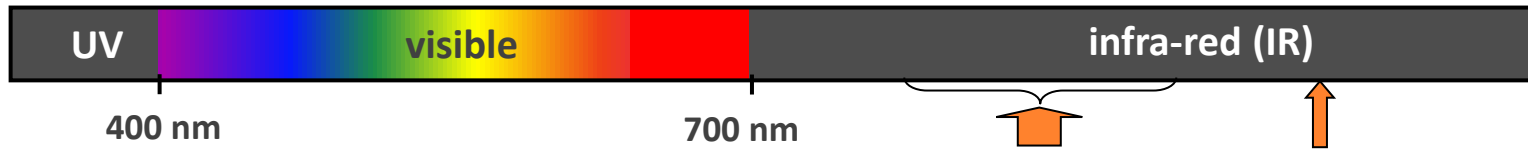

normal camera like
view human eye

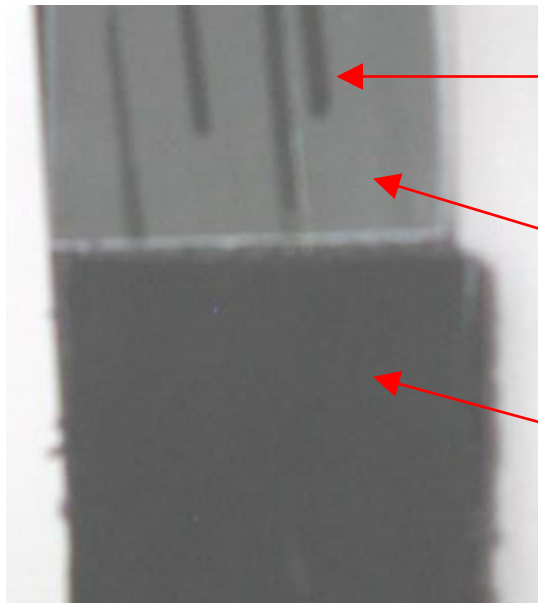

camera with IR-filter
view like the laser

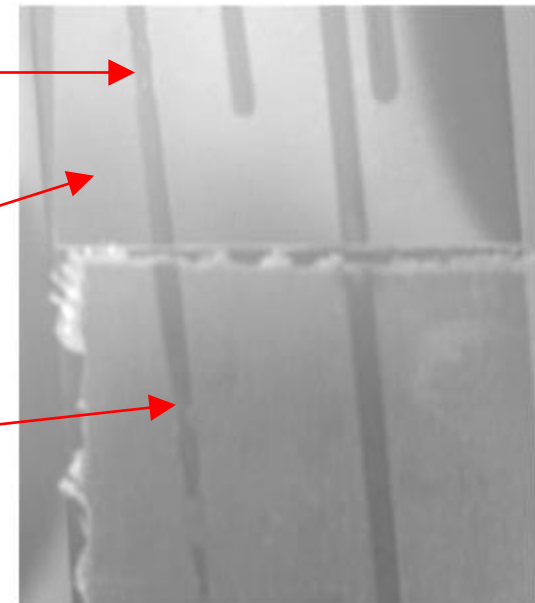

2. Design rules for laser process

Coloring in value chain in plastic and textile industry

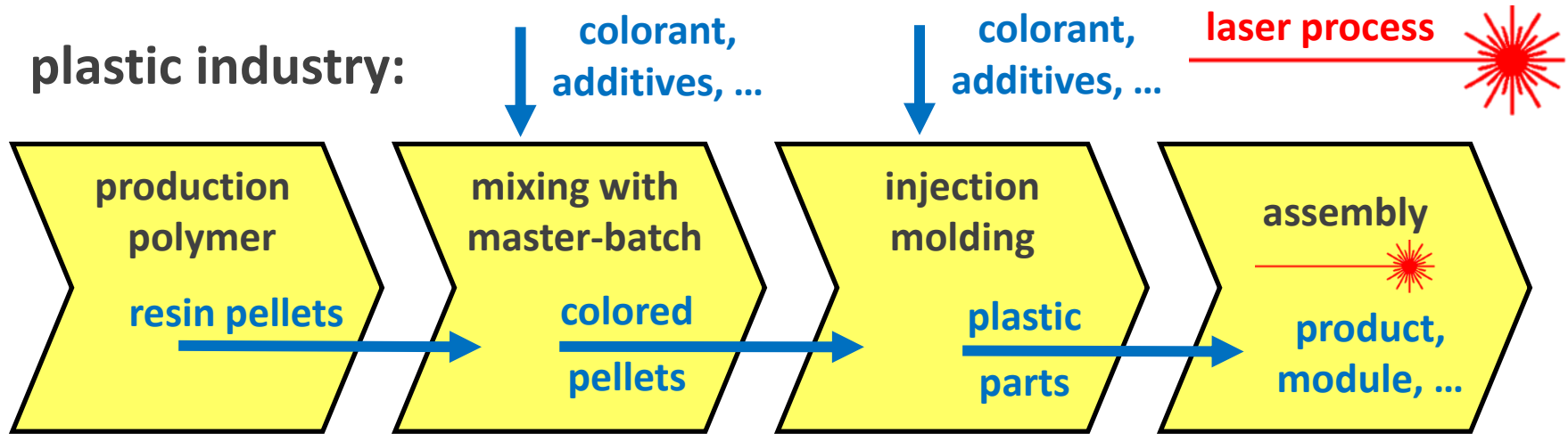

textiles:

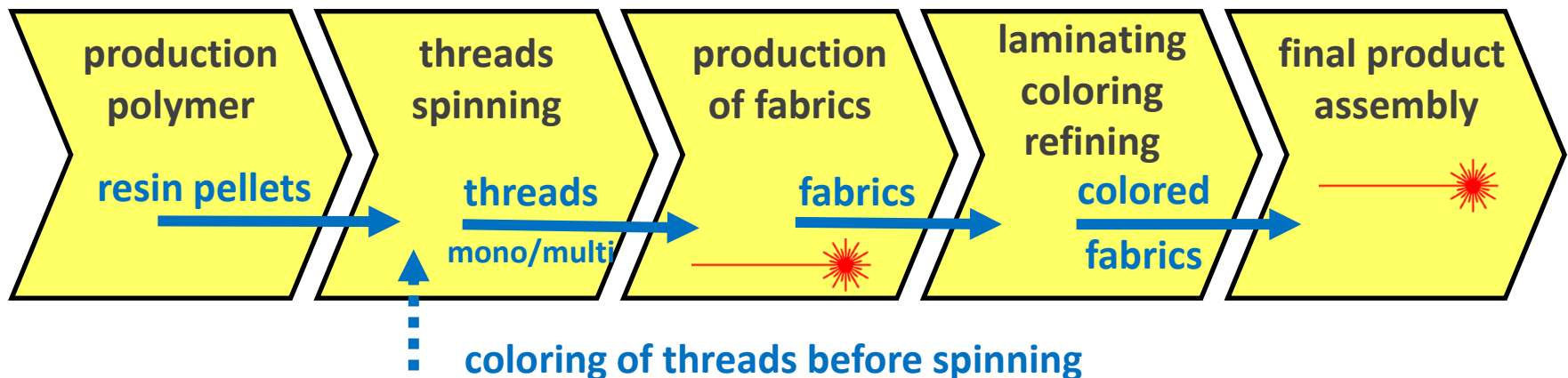

3. Direct laser weld seams

Melting the fibers or themselves

- lower or inner material absorbs laser
- textile fibers melt partly
- no third material necessary
- little marks of weld on the outside
- challenge: supply of laser-absorbing fibers

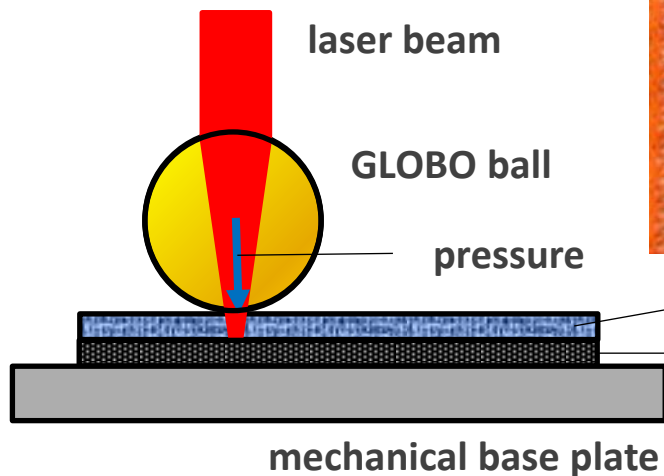
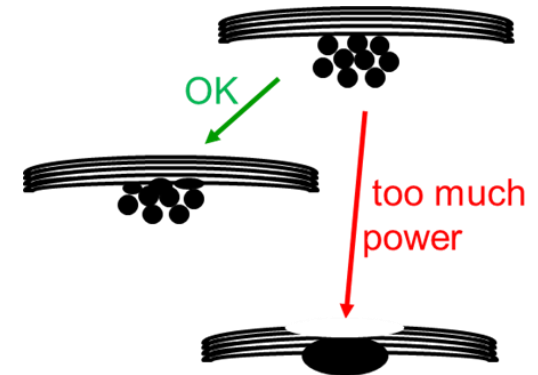

textile 1 transparent
textile 2 absorbing



3. Direct laser weld seams

Little marks of weld seam visible

knitted fabric



ultrasonic welded seam



laser welded seam



sample	friction coefficient	tensile strength (N)
knitted fabric	0.35 +- 0.02	
ultrasonic weld	0.38 +- 0.02	763.07 +- 74.23
laser weld	0.35 +- 0.01	983.56 +- 23.68

measured by EMPA

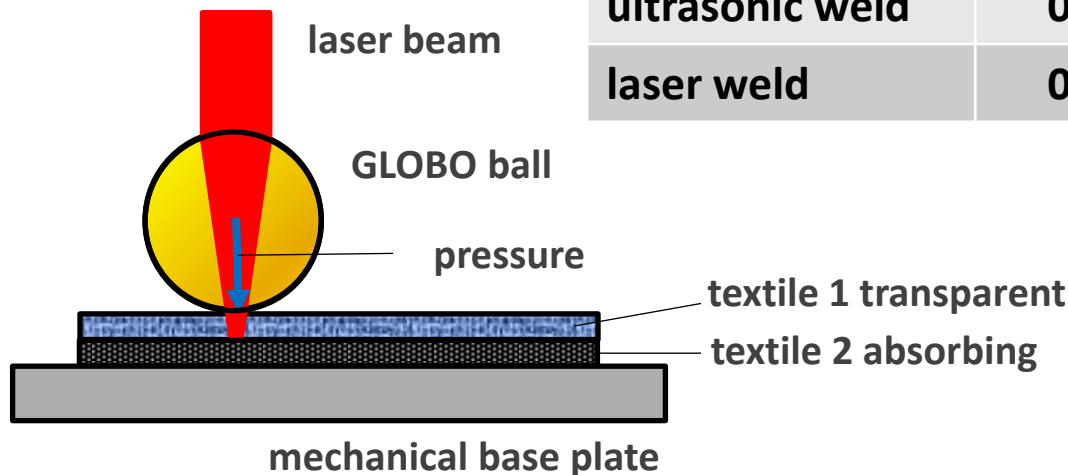

3. Direct laser weld seams

Thin laser absorbing foil between textiles

- easier available: laser-absorbing membrane or film between textiles
 - full two-layer laminate
 - print on membrane (2.5 layer laminate)
 - additional ribbon (challenge handling)
- textile fibers and membrane melt partly
- no marks of weld on outside

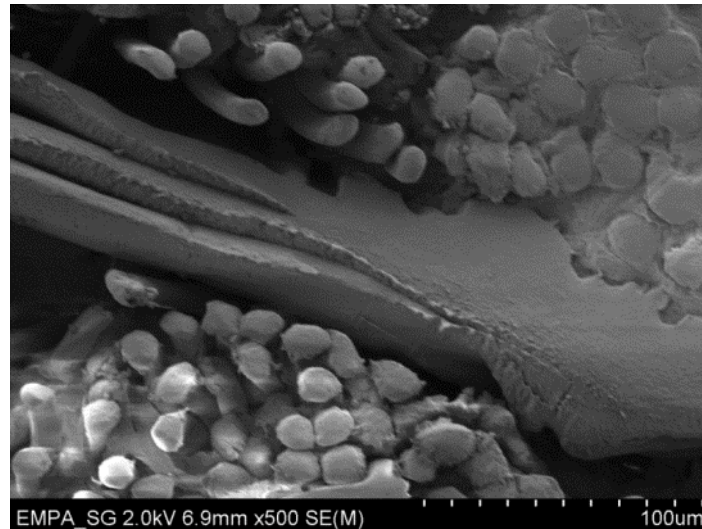
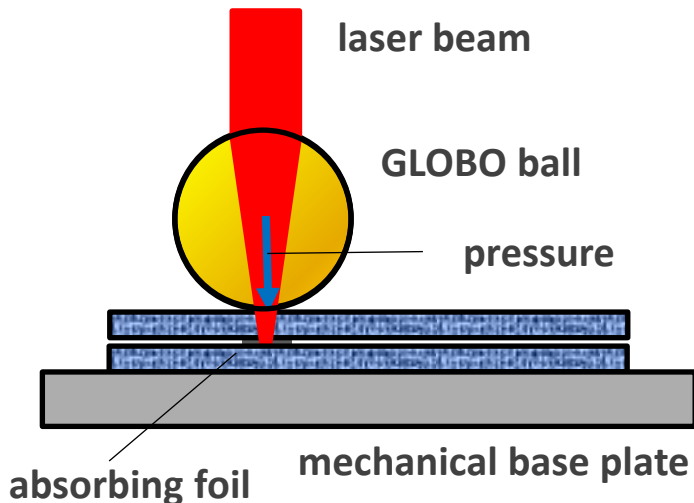

4. Laser bonding

Activating adhesive by laser light

- laser absorbed by adhesive tape activates bonding process
- chemical adhesive or hot-melt
- adhesive one or two sided on tape
- absorption by black tape or special IR-pigment in transparent tape
- disadvantage: - additional tape
- handling of tape

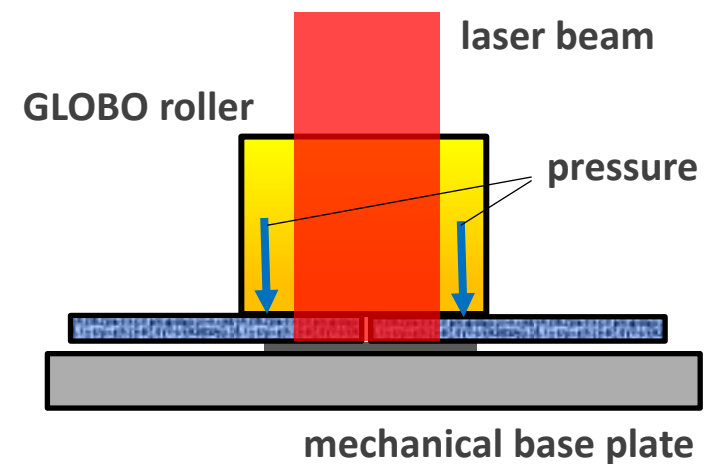
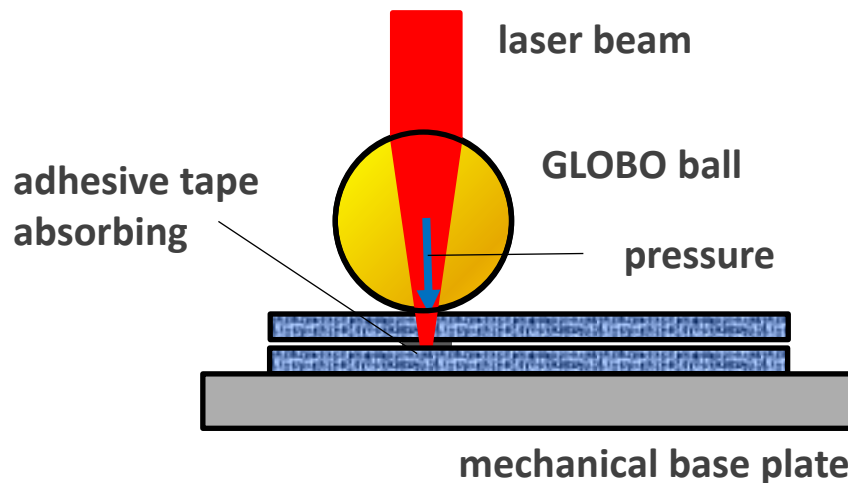
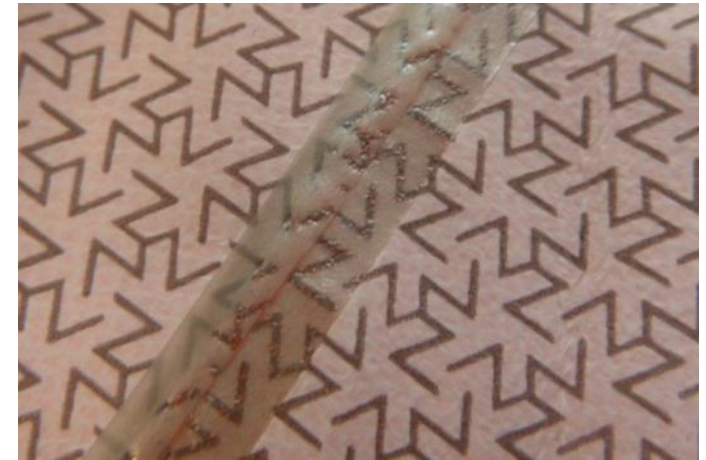

5. Laser taping of sewn seam

Sealing the holes from needles watertight

- traditionally done by hot air: slow
- laser absorbed by adhesive tape activates bonding process
- chemical adhesive or hot-melt
- absorption by black tape or special IR-pigment in transparent tape
- through paper carrier tape possible

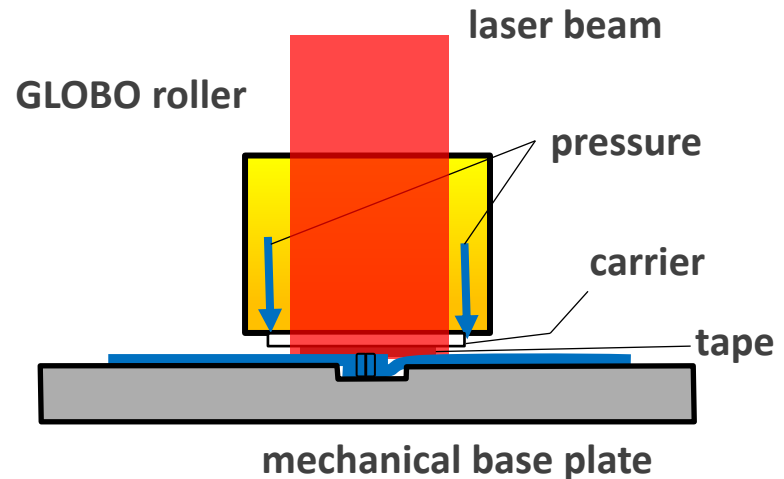
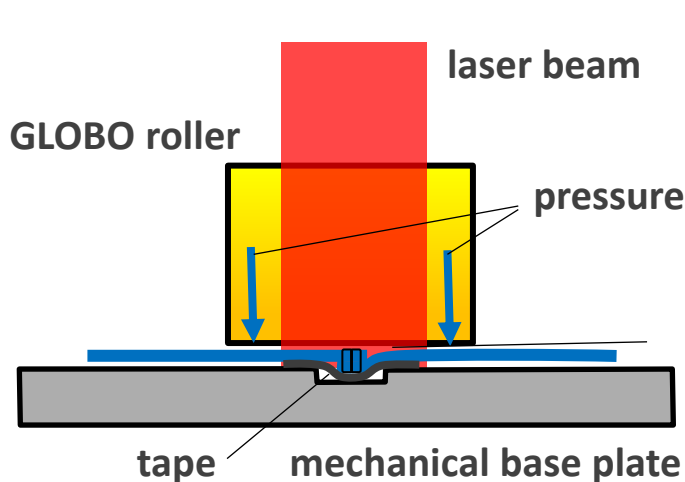

6. Laminating membranes

Laminating membrane on textiles: welding thin membranes on textiles

- thin membrane (μm) on textile – pattern possible by mask
- traditionally adhesive dots or hot pressing
- transparent membrane on laser-absorbing textile
- laser-absorbing membrane on textile – e.g. for welding seam later by laser
- goal: more active breathable area of membrane to reduce RET less

technique	RET ($\text{m}^2 \cdot \text{Pa} / \text{W}$)
material batch	15 ± 0.2
laser laminated	17 ± 0.3
hot melt points	21 ± 0.3

measured by EMPA

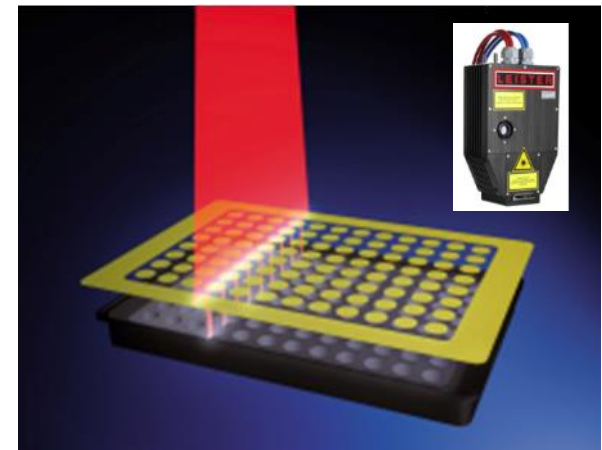

7. Laser safety

Protection of the eyes necessary at open system

needed laser power can damage human eye

⇒ closed system: housing shields laser light

⇒ open system: person next to machine has to wear protection goggles



8. Example: wind-stopper jacket

Swiss Textile School with Laser Seam Welder prototype from Schips

- all seams by laser including zippers
- 2.5 layer laminate with laser-absorbing membrane
- black or gray textile laser-transparent
- roller optics on sewing machine

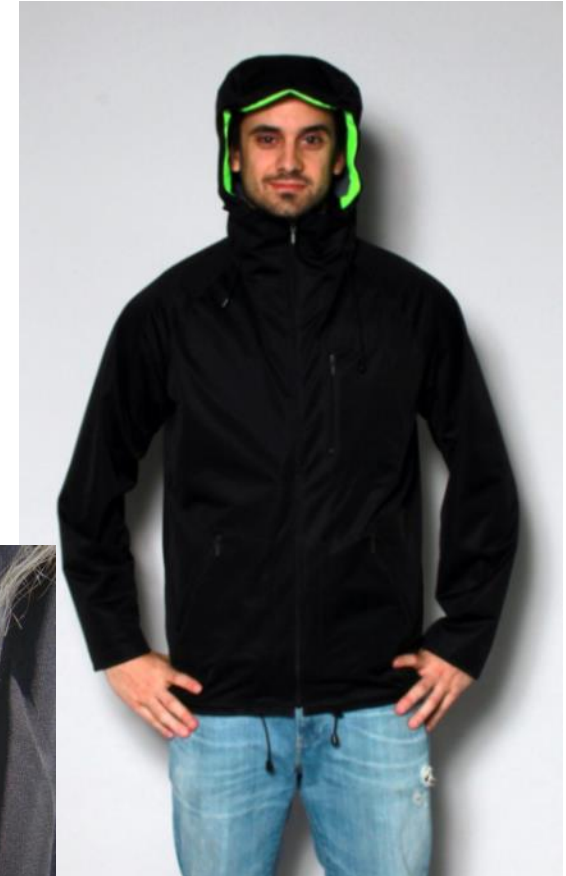

8. Example: inflatable inner jacket

Swiss Textile School with Laser Seam Welder prototype from Schips

- air-tight chambers with down inside
- press air out for low insulation
- self-inflatable for good insulation
- weld thin breathable membranes without punctures

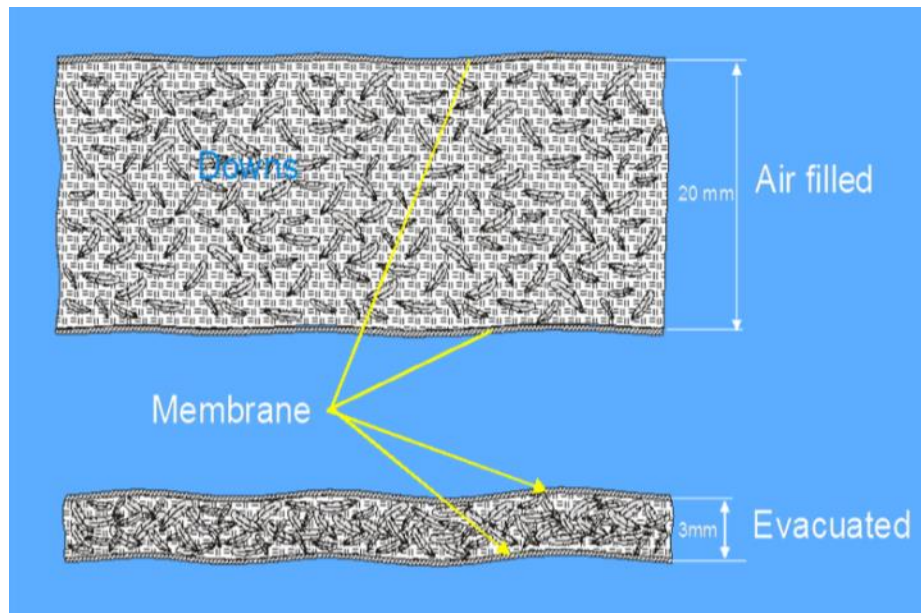

8. Example: Cool-Pads Unico Swiss Tex

Artificial sweating for cooling in medical application and protective wear

challenge:

- join thin polyester membranes to water absorbing polyester textile
- no punctures in the membranes
⇒ no water leaking out
- sealing membranes at the edge of pad

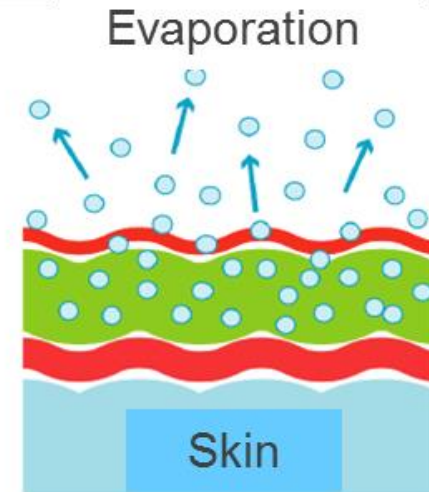
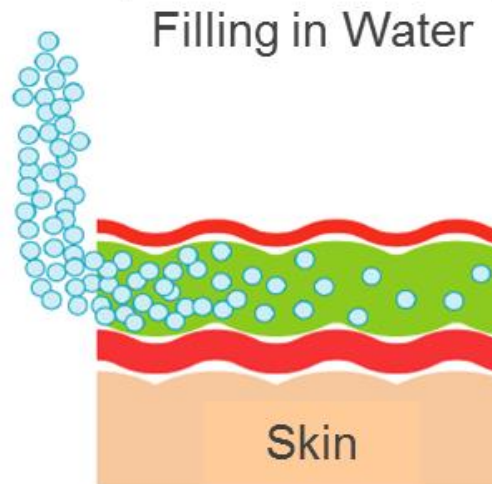
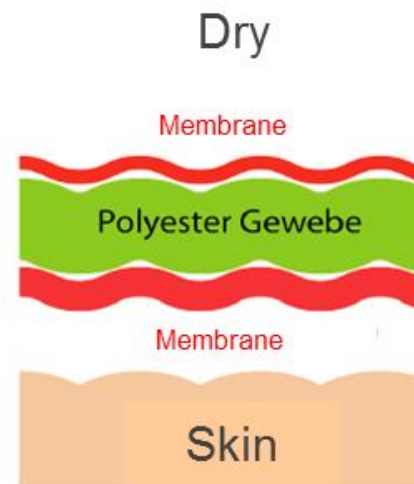
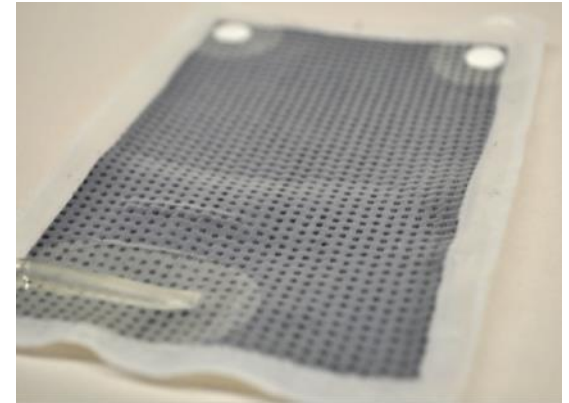

8. Example: Cool-Pads Unico Swiss Tex

Artificial sweating for cooling in medical application and protective wear

solution:

- laminate membrane to laser-absorbing textile by laser mask process
- textile colored with carbon black in melt
- sealing membranes at the edge in melt-through process on laser-absorbing base

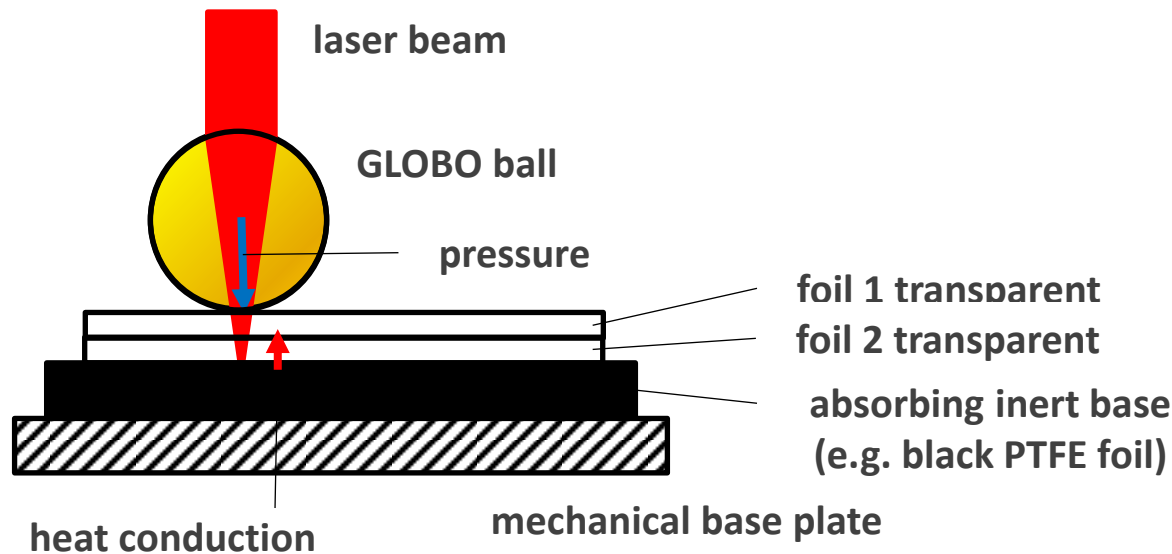
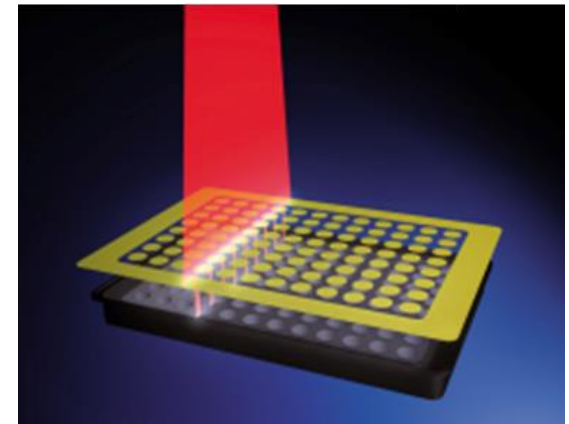
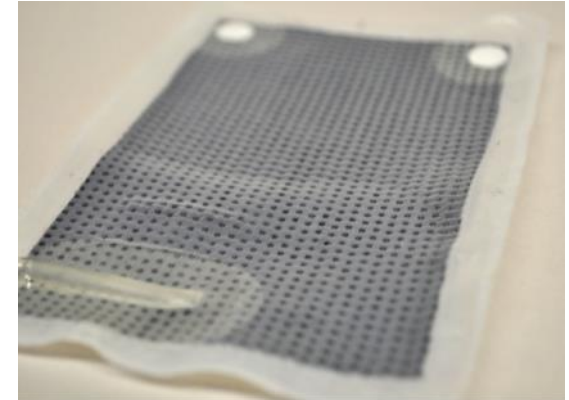

8. Example: Cool-Pads Unico Swiss Tex

Artificial sweating for cooling in medical application and protective wear

Cool-Pads integrated for:

- cooling down patients locally for pain relief
- cooling policeman under bullet-proof vest – air-channels under vest and forced convection by small fan.
- cooling worker in chemical protection suit



THANK YOU FOR YOUR ATTENTION !

- Results part of Swiss National project
«Laser welding of textiles and membranes»
supported by CTI (Commission for Technology & Innovation)
- Academic and industrial partners along the textile value chain
- Target: develop and start to establish laser textile welding as an industrial process

